

# DUY ANSI DUAL SEALS

## Standard Cartridge Seals

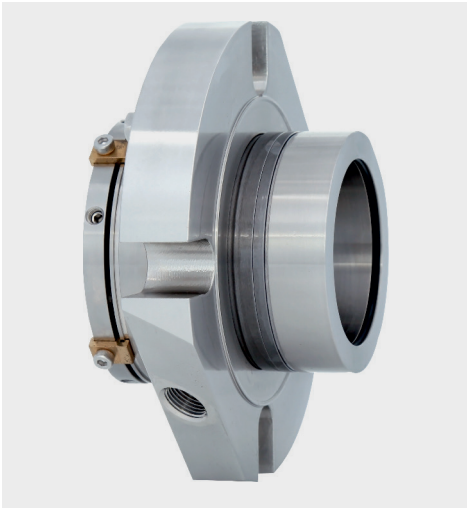

### Product Description

1. Dual seal configuration
2. Balanced design
3. Independent of direction of rotation
4. Cartridge construction
5. Available for standard (CTX-ASDN) and big bore (CTX-ABDN) seal chambers
6. Double pressure balanced
7. Designed with integrated pumping device for increased efficiency in circulation

### Technical Features

1. Ideal for use in ANSI process pumps
2. O-ring is dynamically loaded to prevent shaft damage.
3. Dimensional modification of the stuffing box chamber is not required due to short radial installation height
4. Ideal to convert and retrofit pumps with packings and large volume OEM production
5. Cartridge unit factory assembled for easy installation, which reduces down-time
6. Rugged design for long operating life

### Typical Industrial Applications

ANSI process pumps  
 Chemical industry  
 Food and beverage industry  
 Petrochemical industry  
 Pharmaceutical industry  
 Universally applicable  
 Water and waste water technology

### Standards

ANSI

### Materials

Seal face: Silicon carbide (Q1), Carbon graphite resin impregnated (B), Tungsten carbide (U2)  
 Seat: Silicon carbide (Q1)  
 Secondary seals: FKM (V), EPDM (E), FFKM (K), Perfluorocarbon rubber/PTFE (U1)  
 Springs: Hastelloy® C-4 (M)  
 Metal parts: CrNiMo steel (G), CrNiMo cast steel (G)

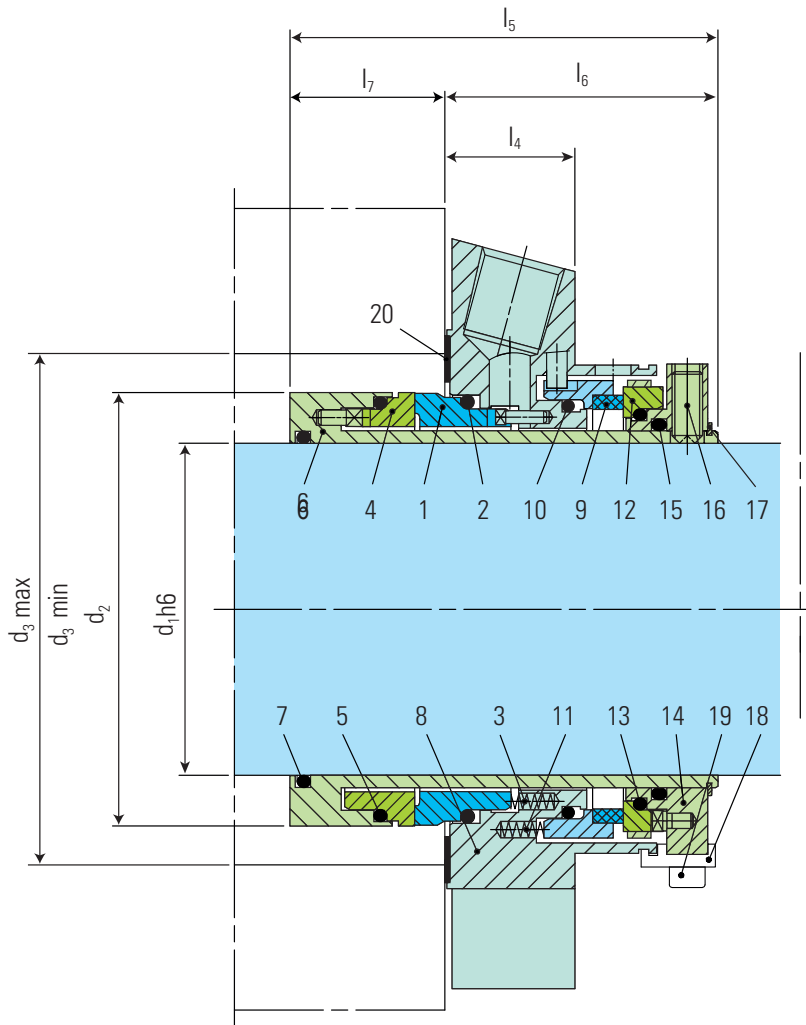

**Note:** The item numbers as depicted above are based on our technical experience and knowledge and are placed in the chronological order of their assembly procedure.

Item	Description
1	Seal face
2, 5, 7, 10, 13, 15	O-ring
3	Spring
4	Seat
6	Shaft sleeve
8	Cover
9	Seal face
11	Spring
12	Seat
14	Drive collar
16	Set screw
17	Snap ring
18	Assembly fixture
19	HSH Cap Screw
20	Gasket
21	Screw plug
22	Gasket



## Installation, Details, Options

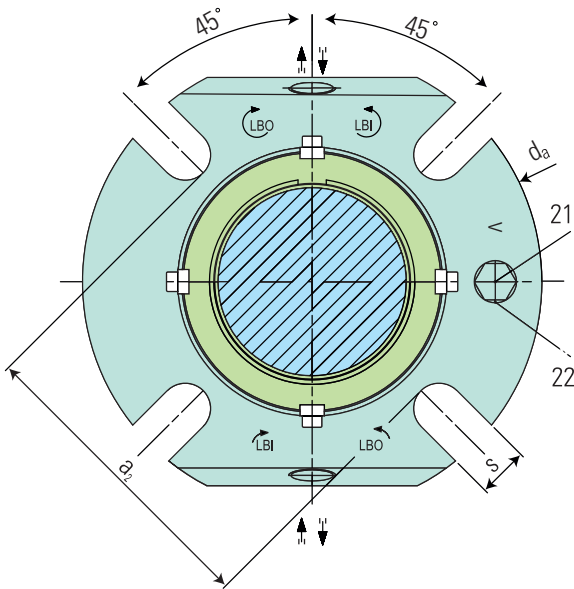

## Performance Capabilities

Sizes:  $d_1 = 1.000'' \dots 3.750''$

Other sizes on request

Temperature:  $t = -40\text{ }^\circ\text{C} \dots +220\text{ }^\circ\text{C}$  ( $-40\text{ }^\circ\text{F} \dots +428\text{ }^\circ\text{F}$ )

(Check O-ring resistance)

### Sliding face material combination BQ1

Pressure:  $p_1 = 25\text{ bar}$  (363 PSI)

Speed = 16 m/s (52 ft/s)

### Sliding face material combination Q1Q1 or U2Q1

Pressure:  $p_1 = 20\text{ bar}$  (290 PSI)

Speed = 10 m/s (33 ft/s)

Barrier fluid circulation system:

$p_{3,max} = 25\text{ bar}$  (363 PSI)

$\Delta p (p_3 - p_1)$  ideal = 2 ... 3 bar (29 ... 44 PSI),

7 bar (102 PSI) for barrier media with poor lubricating properties)

Pump startup:

$\Delta p (p_3 - p_1)_{max} = 25\text{ bar}$  (363 PSI) allowed

Recommended supply medium: max. ISO VG 5

Permissible axial movement:  $\pm 1.0\text{ mm}$ ,  $d_1 > 75\text{ mm} \pm 1.5\text{ mm}$

## Dimensional Data

### BIG BORE - Dimensions in inch

$d_1$	$d_2$	$d_{3min.}$	$d_{3max.}$	$l_4$	$l_5$	$l_6$	$l_7$	$a_2$	$d_a$	$s$	Connection
1.000	-	-	-	-	-	-	-	-	-	-	-
1.125	1.713	1.752	2.795	1.000	3.228	1.886	1.343	3.311	4.500	0.437	1/4 NPT
1.250	-	-	-	-	-	-	-	-	-	-	-
1.375	1.960	2.000	3.189	1.000	3.406	2.083	1.323	3.543	5.118	0.437	1/4 NPT
1.500	-	-	-	-	-	-	-	-	-	-	-
1.625	-	-	-	-	-	-	-	-	-	-	-
1.750	2.461	2.500	4.055	1.000	3.406	2.083	1.323	4.567	6.496	0.559	3/8 NPT
1.875	2.583	2.661	3.937	1.000	3.406	2.083	1.323	4.409	5.984	0.551	3/8 NPT
2.000	2.677	2.756	4.567	1.260	3.406	2.102	1.303	4.882	6.260	0.551	3/8 NPT
2.125	2.834	2.913	4.528	1.000	3.406	2.102	1.303	5.276	6.890	0.709	3/8 NPT
2.250	2.960	3.093	4.409	1.276	3.406	2.102	1.303	4.685	6.417	0.709	3/8 NPT
2.500	3.212	3.299	5.276	1.250	3.406	2.102	1.303	5.512	7.795	0.709	3/8 NPT
2.625	3.338	3.170	5.118	1.250	3.406	2.102	1.303	5.354	6.890	0.709	3/8 NPT
2.750	3.660	3.740	5.236	1.276	3.406	2.102	1.303	5.512	7.480	0.630	3/8 NPT
3.000	3.937	4.016	5.512	1.276	3.406	2.516	1.303	5.906	8.228	0.650	3/8 NPT
3.250	-	-	-	-	-	-	-	-	-	-	-

### STANDARD BORE - Dimensions in inch

$d_1$	$d_2$	$d_{3min.}$	$d_{3max.}$	$l_4$	$l_5$	$l_6$	$l_7$	$a_2$	$d_a$	$s$	Connection
1.000	1.693	1.732	2.205	1.000	3.406	2.102	1.303	2.441	3.937	0.433	1/4 NPT
1.125	1.713	1.752	2.205	1.000	3.228	3.228	1.343	2.441	4.134	0.437	1/4 NPT
1.250	1.969	2.008	2.402	1.000	3.406	2.102	1.303	2.756	4.252	0.433	1/4 NPT
1.375	1.961	2.000	2.402	1.000	3.406	2.083	1.303	2.756	4.213	0.437	1/4 NPT
1.500	2.200	2.244	2.717	1.000	3.406	2.102	1.303	2.953	4.488	0.551	3/8 NPT
1.625	2.340	2.421	2.795	1.000	3.406	2.102	1.303	3.091	4.921	0.551	3/8 NPT
1.750	2.461	2.500	2.953	1.000	3.406	2.102	1.303	3.228	5.118	0.559	3/8 NPT
1.875	2.583	2.661	3.070	1.000	3.406	2.102	1.303	3.307	5.118	0.551	3/8 NPT
2.000	2.677	2.756	3.189	1.000	3.406	2.102	1.303	3.425	5.472	0.630	3/8 NPT
2.125	2.834	2.913	3.583	1.000	3.406	2.102	1.303	3.819	5.512	0.650	3/8 NPT
2.250	2.960	3.039	3.583	1.000	3.406	2.102	1.303	3.858	5.866	0.650	3/8 NPT
2.375	3.070	3.125	3.590	1.000	-	-	-	-	6.181	0.709	3/8 NPT
2.500	3.212	3.291	3.937	1.122	3.406	2.102	1.303	4.528	6.693	0.709	3/8 NPT
2.625	3.338	3.417	4.016	1.250	3.406	2.102	1.303	4.528	6.378	0.630	3/8 NPT
2.750	3.660	3.740	4.370	1.260	3.406	2.102	1.303	4.646	7.441	0.709	3/8 NPT
3.000	3.937	4.016	4.724	1.260	4.252	2.516	1.736	5.000	7.835	0.709	3/8 NPT
3.250	4.189	4.268	4.921	1.260	4.252	2.516	1.736	5.315	7.830	0.709	3/8 NPT
3.750	4.689	4.750	5.433	1.000	-	-	-	-	8.189	0.866	3/8 NPT

**Note:** Additional technical & dimensional information will be provided on request.