

# VUY Single Seals

## Standard Cartridge Seals

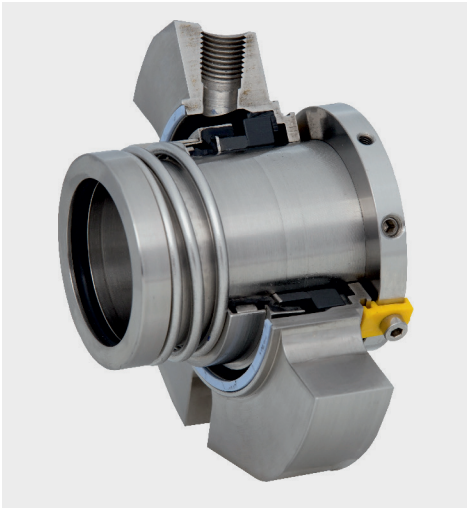

### Product Description

1. Single seal configuration
2. Unbalanced design
3. Independent of direction of rotation
4. Cartridge construction

### Technical Features

1. Ideal for use in process pump standardization
2. Flushing connection according to API 682, Plan 11 for seal chamber cleaning and cooling Low cost
3. cartridge solution
4. Dimensional modification of the stuffing box chamber is not required due to short radial installation height
5. Ideal to convert and retrofit pumps with packings and large volume OEM production
6. Cartridge unit factory assembled for easy installation, which reduces down-time
7. Rugged design for long operating life

### Typical Industrial Applications

Water and waste water technology  
 Sewage water  
 Cold and hot water  
 Cooling fluids  
 Beverages  
 Circulating pumps  
 Water and waste water pumps

### Materials

Seal face: Carbon graphite resin impregnated (B),  
 Silicon carbide (Q1)  
 Seat: Silicon carbide (Q1)  
 Secondary seals: FKM (V), EPDM (E)  
 Metal parts: CrNiMo steel (G),  
 CrNiMo cast steel (G)

### Performance Capabilities

Sizes: Upto 75 mm (1" ... 2.625")  
 Pressure:  $p_1 = 12$  bar (174 PSI)  
 Temperature:  $t = -20$  °C ... +140 °C  
 (-4 °F ... +284 °F)  
 Speed = 10 m/s (33 ft/s)  
 Axial movement:  $\pm 0.5$  mm

### Stationary Seats

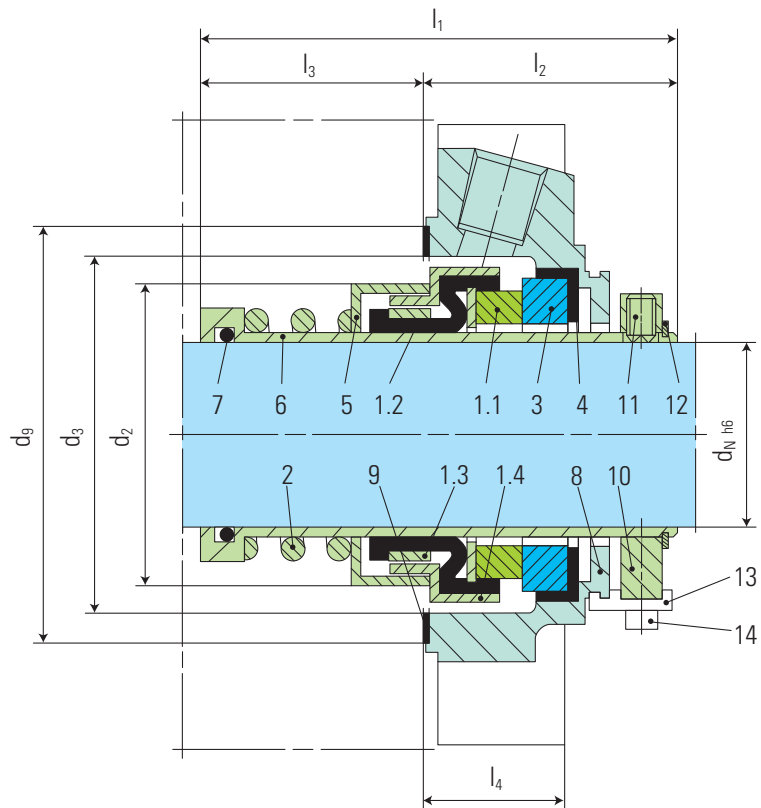
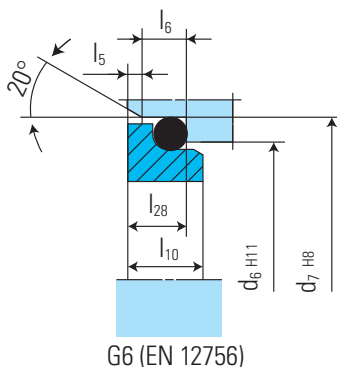

Item	Description
1	Bellows unit
1.1	Seal face
1.2	Bellows
1.3	Drive collar
1.4	L-ring (spring collar)
2	Spring
3	Seat
4	O-ring or L-ring
5	Spacer ring

Item	Description
6	Shaft sleeve
7	O-ring
8	Cover
9	Gasket
10	Drive collar
11	Set screw
12	Snap ring
13	Assembly fixture
14	HSH Cap Screw

**Note:** The item numbers as depicted above are based on our technical experience and knowledge and are placed in the chronological order of their assembly procedure.



## Installation, Details, Options

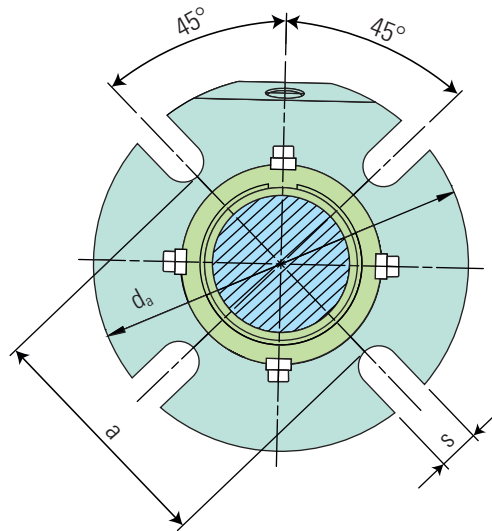

### Dimensional Data

#### Dimensions in inch

d <sub>N</sub>	d <sub>2</sub>	d <sub>3 min</sub>	d <sub>3 max</sub>	d <sub>6</sub>	d <sub>7</sub>	d <sub>9</sub>	d <sub>a</sub>	a	s	h <sub>1</sub>	h <sub>2</sub>	h <sub>3</sub>	h <sub>4</sub>	t
1.000	1.512	1.634	2.000	2.362	4.134	2.440	0.520	2.579	1.614	0.965	0.906	1/4 NPT		
1.125	1.669	1.750	2.050	2.362	4.134	2.441	0.520	2.677	1.634	1.043	0.906	1/4 NPT		
1.250	1.772	1.890	2.250	2.559	4.331	2.638	0.520	2.736	1.654	1.083	0.906	1/4 NPT		
1.375	1.933	2.000	2.420	2.677	4.213	2.756	0.520	2.854	1.732	1.122	1.024	1/4 NPT		
1.500	2.020	2.146	2.625	2.874	4.843	2.950	0.579	2.854	1.732	1.122	1.024	1/4 NPT		
1.750	2.354	2.480	2.812	3.110	5.118	3.230	0.559	3.012	1.752	1.260	1.024	1/4 NPT		
1.875	2.433	2.559	2.940	3.228	5.118	3.307	0.559	3.071	1.772	1.299	1.024	1/4 NPT		
2.000	2.551	2.677	3.190	3.346	5.827	3.430	0.579	3.169	1.850	1.319	1.102	3/8 NPT		
2.125	2.795	2.875	3.437	3.740	5.512	3.820	0.689	3.287	1.850	1.437	1.102	3/8 NPT		
2.250	2.874	2.992	3.560	3.780	6.181	3.858	0.689	3.287	1.850	1.437	1.102	3/8 NPT		
2.375	3.012	3.110	3.590	3.937	6.181	4.020	0.689	3.366	1.850	1.516	1.102	3/8 NPT		
2.500	3.209	3.287	3.800	4.173	6.693	4.252	0.689	3.465	1.909	1.555	1.102	3/8 NPT		
2.625	3.268	3.374	3.937	4.252	6.378	4.331	0.689	3.465	1.909	1.555	1.102	3/8 NPT		

#### Dimensions in millimeter

d <sub>N</sub>	d <sub>2</sub>	d <sub>3 min</sub>	d <sub>3 max</sub>	d <sub>6</sub>	d <sub>7</sub>	d <sub>9</sub>	d <sub>a</sub>	a	s	h <sub>1</sub>	h <sub>2</sub>	h <sub>3</sub>	h <sub>4</sub>	h <sub>5</sub>	h <sub>6</sub>	h <sub>10</sub>	h <sub>28</sub>	t
25	38.4	41.5	51.0	34.0	40	60	105	62	13.2	65.5	41.0	24.5	23	2	5	8.5	7.5	1/4 NPT
28	42.4	44.5	52.0	37.0	43	60	105	62	13.2	68.0	41.5	26.5	23	2	5	8.5	7.5	1/4 NPT
30	42.4	45.5	56.0	39.0	45	63	105	67	13.2	68.0	41.5	26.5	23	2	5	8.5	7.5	1/4 NPT
33	45.0	48.0	57.0	42.0	48	65	110	67	13.2	69.5	42.0	27.5	23	2	5	8.5	7.5	1/4 NPT
35	49.1	50.8	61.5	44.0	50	68	107	70	13.2	72.5	44.0	28.5	26	2	5	8.5	7.5	1/4 NPT
38	51.3	54.5	66.0	49.0	56	73	123	75	14.7	72.5	44.0	28.5	26	2	6	10	9	1/4 NPT
40	54.3	57.5	68.0	51.0	58	75	123	77	14.7	75.5	44.5	31.0	26	2	6	10	9	1/4 NPT
43	56.3	59.5	70.5	54.0	61	78	133	80	14.7	76.5	44.5	32.0	26	2	6	10	9	1/4 NPT
45	59.8	63.0	73.0	56.0	63	79	130	82	14.2	76.5	44.5	32.0	26	2	6	10	9	1/4 NPT
48	61.8	65.0	75.0	59.0	66	82	130	84	14.2	78.0	45.0	33.0	26	2	6	10	9	1/4 NPT
50	64.8	68.0	78.0	62.0	70	85	148	87	14.7	80.5	47.0	33.5	28	2.5	6	10.5	9.5	3/8 NPT
53	71.0	73.0	87.0	65.0	73	95	148	97	17.5	81.5	47.0	34.5	28	2.5	6	12	11	3/8 NPT
55	71.0	73.0	83.0	67.0	75	90	148	92	17.5	83.5	47.0	36.5	28	2.5	6	12	11	3/8 NPT
60	76.5	79.0	91.0	72.0	80	100	157	102	17.5	85.5	47.0	38.5	28	2.5	6	12	11	3/8 NPT
65	83.0	85.7	98.5	77.0	85	108	162	110	17.5	88.0	48.5	39.5	28	2.5	6	12	11	3/8 NPT
70	88.0	94.0	108.0	83.0	92	116	178	118	17.5	92.0	48.5	43.5	28	2.5	7	12.5	11.3	3/8 NPT
75	93.4	98.4	118.0	88.0	97	125	190	127	17.5	93.5	49.0	44.5	28	2.5	7	12.5	11.3	3/8 NPT

Note: Additional technical & dimensional information will be provided on request.