

DUYBQJ Single & Dual Seals

Standard Cartridge Seals



Product Description

1. Single and Dual seal configuration
2. Balanced design
3. Independent of direction of rotation
4. Cartridge construction
5. Seal design in accordance with API 682/ ISO 21049
6. Conforming to Category 1, Type A, Arrangement 1, 2 or 3
7. Single seal with API Plan 11 and 61
8. Dual seals with API Plan 52 / 53
9. Robust construction with shrink-fitted seal faces
10. Heavy duty solid seat design
11. Also available in design variation for independent of direction of rotation
12. Additional flushing plans available on request

Technical Features

1. Designed to accommodate shaft deflections and process fluctuations
2. Efficient construction for heat dissipation
3. Compact installation design
4. Factory assembled cartridge unit for easy installation
5. Springs are product protected to avoid contamination
6. Can accommodate reverse pressure
7. Can handle extensive applications in various temperatures and pressures
8. Versatile in design to fit various seal chambers

Typical Industrial Applications

Chemical industry
 Light volatile and highly viscous hydrocarbons
 Low solids content and low abrasive media
 Media with poor lubrication properties
 Oil and gas industry
 Petrochemical industry
 Toxic and hazardous media
 Standard pumps
 Vertical and horizontal ANSI chemical pumps

Standards

API 682 / ISO 21049

Materials

Seal face: Carbon graphite antimony impregnated (A), Silicon carbide sintered pressureless (Q12)
 Seat: Silicon carbide sintered pressureless (Q1)
 Secondary seals: FKM (V), FFKM (K), NBR (P), EPDM (E)
 Springs: Hastelloy® C-4 (M)* and C-276 (M5)
 Metal parts: CrNiMo steel (G)

Performance Capabilities

Sizes: d_1 = Upto 110 mm (Upto 4.250")
 other sizes on request
 Pressure: p_1 = 22 bar (319 PSI)
 Temperature: t = - 40 °C...+ 260 °C
 (- 40 °F...+ 500 °F)
 Speed = 23 m/s (75 ft/s)

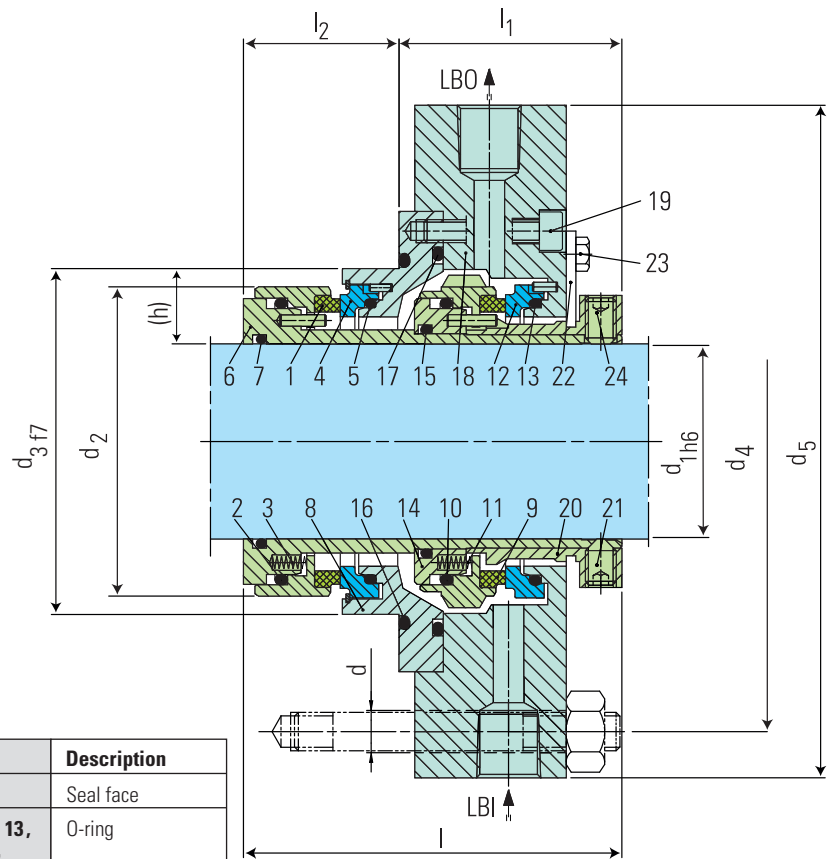

Item	Description
1, 9	Seal face
2, 5, 7, 10, 13, 15, 16, 17	O-ring
3, 11	Spring
4, 12	Seat
6	Shaft sleeve
8	Adapter
14	Driver
18	Housing
19	HSH Cap screw
20	Set ring
21	Set screw
22	Assembly fixture
23	Hexagon bolt
24	Set screw

Note: The item numbers as depicted above are based on our technical experience and knowledge and are placed in the chronological order of their assembly procedure.



Design Variations

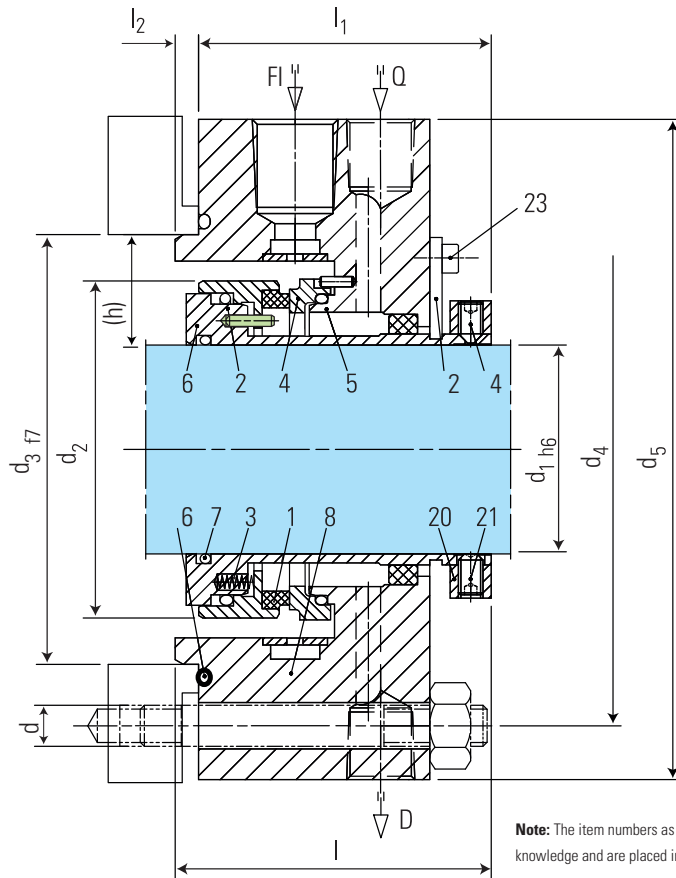

CTXAPI-SA

Single Seal

Dimensional Data

Dimensions in millimeter

d1	d2	d3	d4	d5	l	l1	l2	d	n	acc. to ASME B73.1 (h min)
20	50.4	58	105	127	96.5	68.5	28	13.5	4	19.05
25	55.4	63	110	132	96.5	68.5	28	13.5	4	19.05
30	60.4	68	115	137	96.5	68.5	28	13.5	4	19.05
35	65.4	73	120	142	96.5	68.5	28	13.5	4	19.05
40	70.4	78	125	147	96.5	68.5	28	13.5	4	19.05
45	75.4	83	135	162	96.5	68.5	28	17.5	4	19.05
50	80.4	88	140	167	100	72	28	17.5	4	19.05
55	85.4	93	145	172	100	72	28	17.5	4	19.05
60	96	105	160	187	127.5	88	39.5	17.5	4	22.22
65	101	110	165	192	127.5	88	39.5	17.5	4	22.22
70	106	115	170	197	127.5	88	39.5	17.5	4	22.22
75	111	120	175	202	127.5	88	39.5	17.5	4	22.22
80	116	125	185	213	127.5	88	39.5	22	4	22.22
85	123.5	136	190	223	131.5	92	39.5	22	4	25.4
90	128.5	141	195	228	131.5	92	39.5	22	4	25.4
95	133.5	146	200	233	131.5	92	39.5	22	4	25.4
100	138.5	151	205	238	131.5	92	39.5	22	4	25.4
105	143.5	156	210	243	131.5	92	39.5	22	4	25.4
110	152.5	161	215	248	131.5	92	39.5	22	4	25.4

inch size available from size 0.750 to 4.250

Note: Additional technical & dimensional information will be provided on request.