

# CS Single & Dual Seals Mechanical Seals For Pumps - Engineered Seals

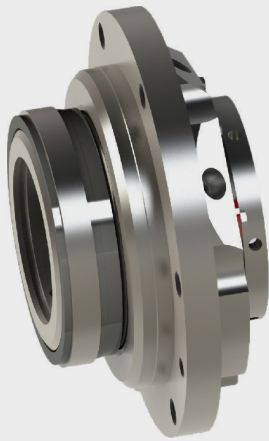

## Product Description

1. Single and Dual seal configuration
2. Balanced design
3. Independent of direction of rotation
4. Cartridge construction
5. Stationary design with multiple springs
6. Seat arrangement is designed behind the impeller
7. Seat design is rotary
8. Specially designed sleeve to protect the springs from contamination
9. Variable designs available with guide sleeve for applications with or without quench

## Technical Features

1. Accommodates shaft deflections due to stationary design
2. Designed to handle media containing solids
3. O-ring is dynamically loaded to prevent shaft damage.
4. Can operate under vacuum without locking the seat
5. Pumping device available for increased efficiency in circulation
6. Springs are product protected to avoid contamination

## Typical Industrial Applications

Water and waste water technology  
 Dirty, abrasive and solids containing media  
 Dredger pumps  
 Mining industry  
 Oil and gas industry  
 Oil sand extraction plants  
 Power plant technology  
 Pulp and paper industry  
 Sewage water pumps  
 Scrubbers in FGD plants

## Performance Capabilities

Sizes:  $d_N =$  Upto 270 mm (Upto 10.625")  
 Pressure:  $p_1^* =$  16 bar (230 PSI)  
 Temperature:  $t = -20\text{ }^\circ\text{C} \dots +160\text{ }^\circ\text{C}$   
 ( $-4\text{ }^\circ\text{F} \dots +320\text{ }^\circ\text{F}$ )  
 Speed = 10 m/s (33 ft/s)  
 \*) For operation under vacuum it is necessary to arrange for quenching on the atmosphere side.

## Standards

EN 12756

## Materials

Seal face: Silicon carbide (Q1, Q2)  
 Seat: Silicon carbide (Q1, Q2)

## Notes

Direction of installation:  
 From the impeller side: BR100  
 From the bearing side: BR110

## Stationary Seats

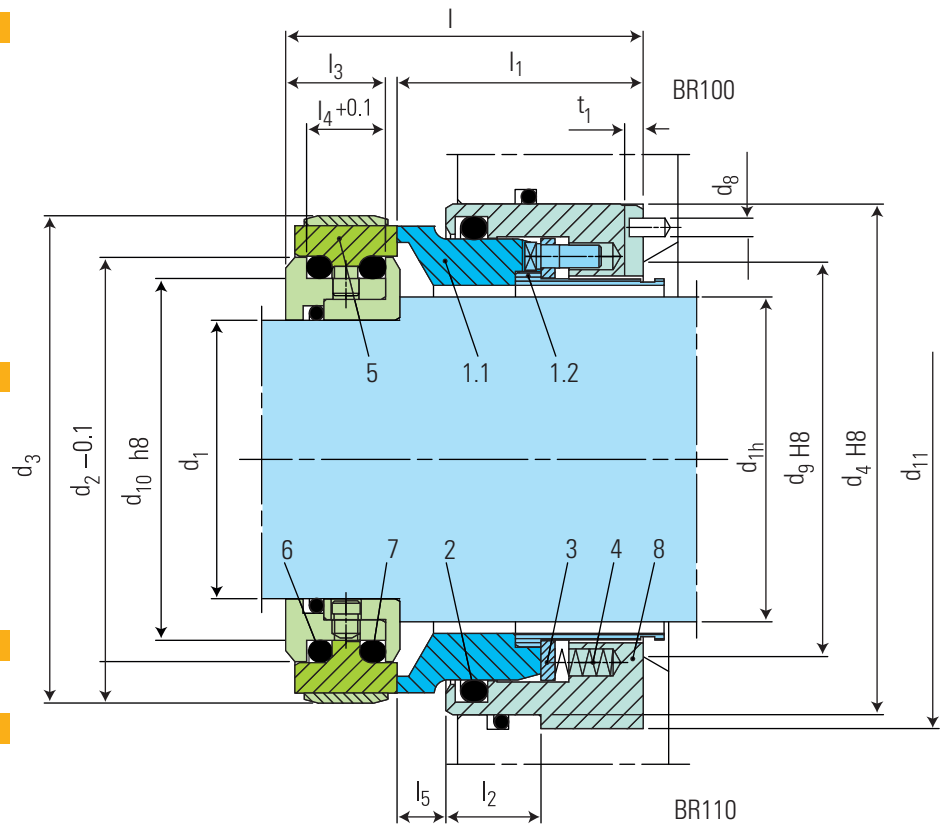
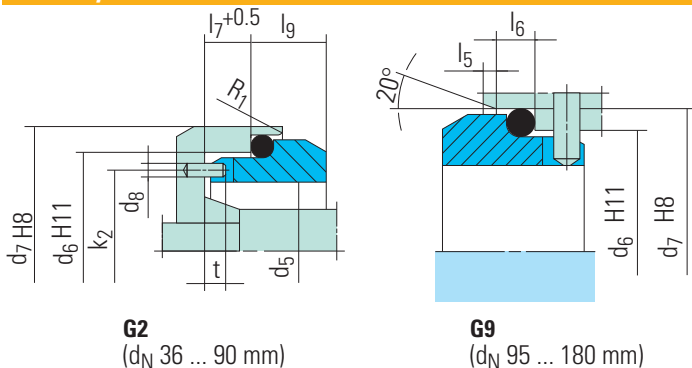

**Note:** The item numbers as depicted above are based on our technical experience and knowledge and are placed in the chronological order of their assembly procedure.

Item	Part no.	Description
1.1	472	Seal face
1.2	520	Sleeve
2	412.1	O-ring
3	474	Thrust ring
4	477	Spring
5	475	Seat (G11)
6	412.2	O-ring
7	412.3	O-ring
8	441	Housing

**DIN 24250**

Direction of installation:- from the impeller side BR100 from the bearing side BR110



## Design Variations

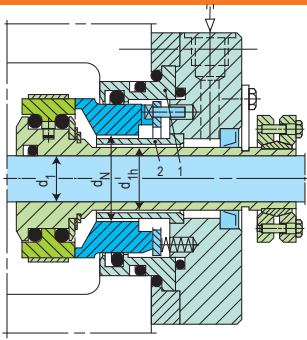

### BR200

Cartridge-type single seal with guide sleeve (Item no. 2) for use with quench. Insert (Item no. 1) either metal or silicon carbide

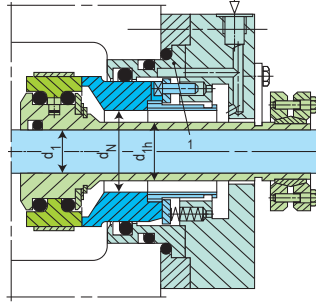

### BR300

Cartridge-type single seal. Insert (Item no. 1) either metal or silicon carbide.  
Optional without maintenance rinsing.

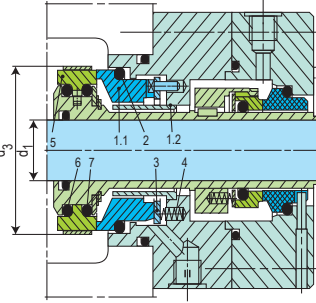

### BRKS-D

Double seal in cartridge design for operation in barrier or buffer pressure (does not open if barrier pressure fails), available alternatively with a pumping screw for a higher rate of circulation. Torque transmission e.g. by shrink disk.

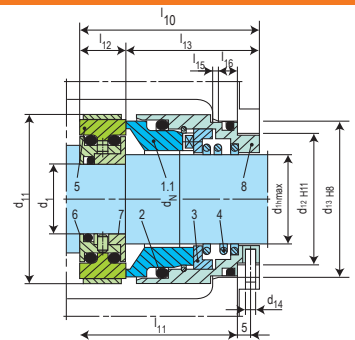

### BRZ100

Single seal with cylindrical spring and type G76 seat. For installation in covers with installation dimensions according to EN 12756 B or U. Installation length  $l_{11}$  corresponds to max.  $l_{1k}$ . Intermediate sizes on request.

## Dimensional Data

### Dimensions in millimeter

$d_1$	$d_{1h}$	$d_N$	$d_2$	$d_3$	$d_4$	$d_5$	$d_6$	$d_7$	$d_8$	$d_9$	$d_{10}$	$d_{11}$ +0.2min	$l$	$l_1$	$l_2$	$l_3$	$l_4$	$l_5$	$l_6$	$l_7$	$l_9$	$k_2$	$t$	$t_1$
20	28	36	47.1	65	70	46	56	63	4	40	38	75	75	53	20	19.5	17	10.5	6	9	8	51	4.5	3
25	33	41	52.1	70	75	51	62	70	4	45	43	80	75	53	20	19.5	17	10.5	6	9	9.5	56.5	4.5	3
28	38	46	57.1	75	80	56	67	75	4	50	48	85	75	53	20	19.5	17	10.5	6	9	9.5	61.5	4.5	3
33	43	51	62.1	80	85	61	72	80	4	55	53	90	75	53	20	19.5	17	10.5	6	9	10.5	66.5	4.5	3
38	48	56	67.1	85	90	66	77	85	4	60	58	95	75	53	20	19.5	17	10.5	6	9	10.5	71.5	4.5	3
43	53	61	72.1	90	95	69	81	90	4	65	63	100	75	53	20	19.5	17	10.5	7	9	11	75	4.5	3
48	58	66	77.1	95	100	76	88	97	4	70	68	105	75	53	20	19.5	17	10.5	7	9	11.5	82	4.5	3
53	63	71	82.1	101	105	81	95	105	4	75	73	110	75	53	20	19.5	17	10.5	7	9	11.5	88	4.5	3
55	65	75	87.1	106	110	86	100	110	4	79	78	115	75	53	20	19.5	17	10.5	7	9	11.5	93	4.5	3
60	70	80	92.1	111	115	91	105	115	4	84	83	120	75	53	20	19.5	17	10.5	7	9	13	98	4.5	3
65	75	85	97.1	116	120	96	110	120	4	89	88	125	75	53	20	19.5	17	10.5	7	9	13	103	4.5	3
70	80	90	102.1	121	125	101	115	125	4	94	93	130	75	53	20	19.5	17	10.5	7	9	13	108	4.5	3
75	85	95	107.1	126	130	107	122.2	134.3	5	99	98	135	75	53	20	19.5	17	10.5	10	12	20	114.5	7	3
80	90	100	112.1	131	135	107	122.2	134.3	5	104	103	140	75	53	20	19.5	17	10.5	10	12	20	114.5	7	3
90	100	110	126.1	147	155	117	136.2	148.3	5	116	117	163	98	73	30	22	19	16.0	10	12	20	126.5	7	4
100	110	120	136.1	157	165	132	146.2	158.3	5	126	127	173	98	73	30	22	19	16.0	10	12	20	139	7	4
110	120	130	145.1	167	175	142	156.2	168.3	5	136	136	183	98	73	30	22	19	16.0	10	12	20	149	7	4
120	130	140	154.1	177	185	152	168.2	180.3	5	146	145	193	98	73	30	22	19	16.0	10	12	22	160	7	4
130	140	150	163.9	188	195	162	178.2	190.3	5	156	155	203	98	73	30	22	19	16.0	12	12	24	170	7	4
140	150	160	174.9	189	205	172	188.2	200.3	5	166	166	213	98	73	30	22	19	16.0	12	12	24	180	7	4
160	170	180	193.9	220	230	187	212.5	224.3	5	186	185	238	98	73	30	22	19	16.0	12	12	28	199.5	7	4
180	190	200	213.9	240	255	-	-	-	-	206	205	265	98	73	30	22	19	16.0	-	-	-	-	-	4
190	200	210	231.9	255	270	-	-	-	-	218	220	280	115	83	40	28.35	24.7	19.0	-	-	-	-	-	5
200	210	220	241.9	265	280	-	-	-	-	228	230	290	115	83	40	28.35	24.7	19.0	-	-	-	-	-	5
210	220	230	251.9	275	290	-	-	-	-	238	240	300	115	83	40	28.35	24.7	19.0	-	-	-	-	-	5
220	230	240	261.9	285	300	-	-	-	-	248	250	310	115	83	40	28.35	24.7	19.0	-	-	-	-	-	5
230	240	250	271.9	295	310	-	-	-	-	258	260	320	115	83	40	28.35	24.7	19.0	-	-	-	-	-	5
250	260	270	291.9	315	330	-	-	-	-	278	280	340	115	83	40	28.35	24.7	19.0	-	-	-	-	-	5

### BRZ100 Dimensional Data

### Dimensions in millimeter

$d_N$	$d_{1h}$	$d_1$	$d_{11}$	$d_{12}$	$d_{13}$	$d_{14}$	$l_{10}$	$l_{11}$	$l_{12}$	$l_{13}$	$l_{15}$	$l_{16}$
35	33	20	56	42	48	3	57.7	49.2	15	42.7	2	5
43	39	27	67	54	61	4	57.7	9.2	5	2.7		6
54	50	35	78	65	73	4	59.8	2.1	5.5	4.3	.5	6
66	60	47	91	77	85	4	66	8	6.5	9.5	.5	6
77	72	55	103	88	97	4	74.5	6	7.5	7	.5	7
100	90	70	125	110	120	4	82	3	1	1		7

Dimensions for shaft diameters from 250 mm on request.  
inch size available from size 0.750 to 10.625

Note: Additional technical & dimensional information will be provided on request.