

# DUY-HTEO Dual Seals

## Standard Cartridge Seals For Pumps - Gas Lubricated



### Product Description

1. Dual seal configuration
2. Balanced design
3. Cartridge construction
4. Stationary design with multiple springs
5. Seat design is rotary
6. Designed to remain in closed position in the event of buffer pressure failure,
7. Can accommodate reverse pressure
8. Gas-lubricated design
9. Gas grooves design is available in V-grooves and U-grooves (independent of direction of rotation)

### Technical Features

1. Seal faces are designed to be non-contacting during operation
2. Designed for environmental protection with high efficiency
3. Due to non-contacting design there is no friction on the seal faces and there is no heat generated at the seal or in the medium
4. Trouble free operations as complex components are not required to dissipate frictional heat

### Typical Industrial Applications

- Chemical industry
- Refining technology
- Gases and liquids
- Media which require high purity
- Environmental harmful media
- Pumps

### Materials

- Seal face: Silicon carbide (Q1/Q19)
- Seat: Silicon carbide (Q19/Q1)
- Secondary seals: FKM (V), EPDM (E), FFKM (K)
- Spring: Hastelloy® C-4 (M)
- Metal parts: CrNiMo steel (G), Hastelloy® C-4 (M)

### Performance Capabilities

- Shaft diameter:  $d_1 = 30 \dots 100 \text{ mm}$  (1.18" ... 3.94")
- Pressure:  $p_1 = 13 \text{ bar}$  (189 PSI),  $p_3 = 16 \text{ bar}$  (232 PSI) with V-grooves (uni-directional)
- $p_1 = 9 \text{ bar}$  (131 PSI),  $p_3 = 12 \text{ bar}$  (174 PSI) with U-grooves (bi-directional)
- Differential pressure ( $p_3 - p_1$ ) = min. 3 bar (44 PSI)
- Operating temperature limits for:
  - EPDM -20 °C ... +140 °C (-4 °F ... +284 °F)
  - FFKM -20 °C ... +120 °C (-4 °F ... +248 °F)
  - FKM -20 °C ... +170 °C (-4 °F ... +338 °F)
- Speed = 4 ... 15 m/s (13 ... 49 ft/s)
- Axial movement:  $\pm 1.0 \text{ mm}$

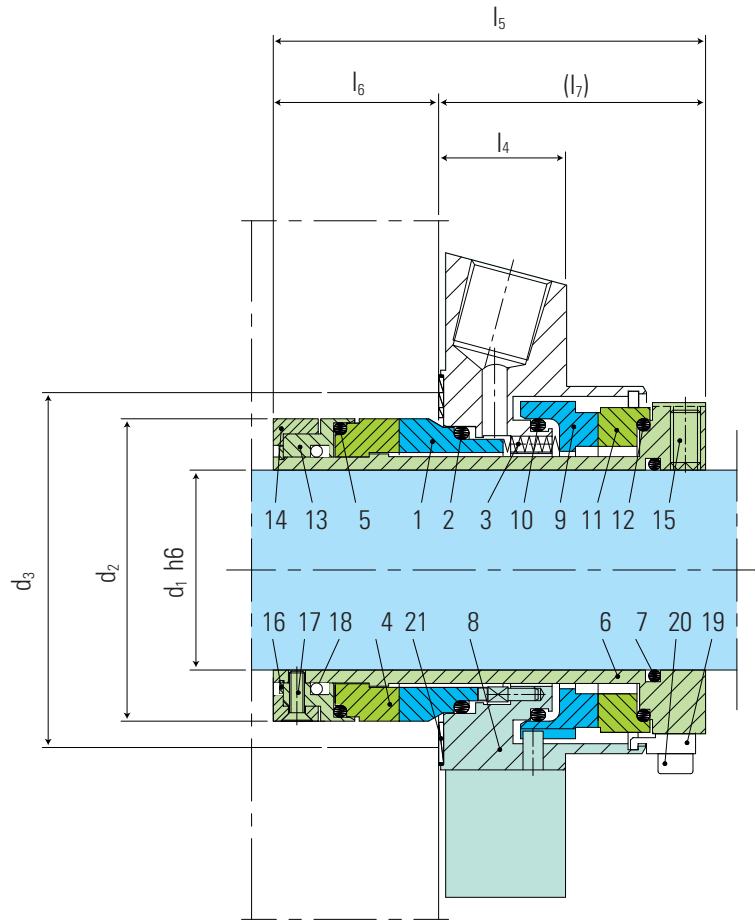

**Note:** The item numbers as depicted above are based on our technical experience and knowledge and are placed in the chronological order of their assembly procedure.

Item	Description
1,9	Seal face
2,5,7,10,12,18	O-ring
3	Spring
4,11	Seat
6	Shaft sleeve
8	Cover
13	Adapter

Item	Description
14	Ring
15	Set screw
16	Retaining ring
17	Counter-sunk socket screw
19	Assembly fixture
20	HSH Cap Screw
21	Gasket

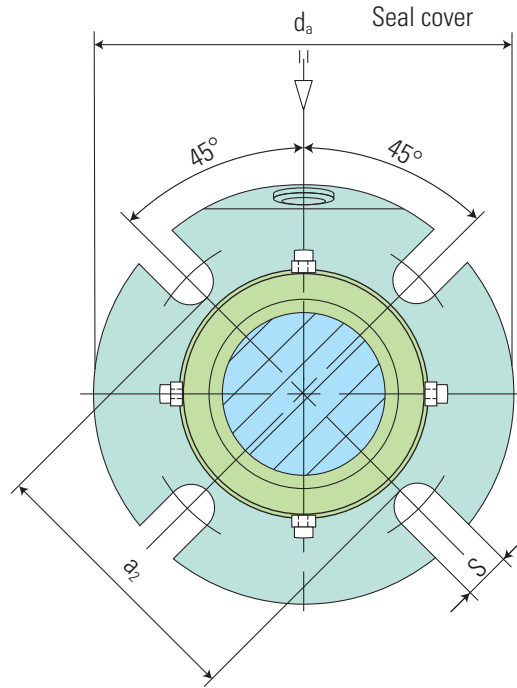

### Dimensional Data

#### Dimensions in millimeter

d1	d2	d <sub>3</sub> min.	d <sub>3</sub> max.	l <sub>4</sub>	l <sub>5</sub>	l <sub>6</sub>	l <sub>7</sub>	a <sub>2</sub>	d <sub>a</sub>	s
30	52.0	54	57	25.4	86	33	53	67	105	14
33	55.0	57	60	25.4	86	33	53	70	108	14
35	57.5	59	62	25.4	86	33	53	72	110	14
38	61.0	63	70	25.4	86	33	53	75	123	14
40	61.0	63	70	25.4	86	33	53	77	123	16
43	64.0	66	70	25.4	86	33	53	80	133	16
45	67.0	68	75	25.4	86	33	53	82	138	16
48	70.0	71	77	25.4	86	33	53	85	138	16
50	71.0	73	78	25.4	86	33	53	87	148	16
53	75.3	77	82	28.5	89	33	56	97	148	18
60	83.5	85	90	28.5	89	33	56	104	155	18
65	93.0	95	102	25.4	100	41.6	58.4	116	163	18
70	101.0	102	110	25.4	100	41.6	58.4	124	178	18
75	107.0	108	119	28	107	41.6	65.4	129	193	18
80	111.0	111	124	28	107	41.6	65.4	129	198	18
90	121.0	121	131	28	107	41.6	65.4	140	205	22
100	130.0	132	144	28	107	41.6	65.4	154	218	22

Note: Additional technical & dimensional information will be provided on request.